



**INCREMENTAL
SAFETY**

SIL3 FUNCTIONAL
IEC 61508 SAFETY
SENSOR

PLe FUNCTIONAL
ISO 13849 SAFETY
SENSOR

- SIL3 / PLe (CAT4) certification
- UL® certificate on request
- Robust mechanical construction with high vibration and shock resistance
- Housing: Design form 58, aluminium, coated zinc alloy / cast zinc alloy
- Shaft type, AISI 303 stainless steel:
 - Blind hollow shaft, 10, 12 or 14 mm
 - Tapered blind hollow shaft, 7.3 mm/10 %
- Output:
 - Digital TTL (RS422) or HTL
 - SIN/COS 1 Vpp
- Resolution: 250 to 2500 counts / 360°
- Operating temperature: - 20 °C to + 85 °C
- Protection grade: IP65
- Suitable for safe motor feedback systems

KEY INFORMATION OVERVIEW

DESIGN & FUNCTION

Sensing the angle position and signal processing including the generation of the SIN/COS signals or the square-wave pulses respectively. Digital signals TTL and HTL are computed from sine/cosine signals.

The safety function ensured by the device is to convert a mechanical rotation into secured electrical information readable by electronics.

Functional safety design due to IEC 61508: SIL3 and ISO 13849: PLe (CAT4) in a robust housing made of aluminium and/or coated or cast zinc alloy with protection grade IP65.

Optionally a UL® certificate can be provided.

- Design form 58 with blind hollow shaft or tapered blind hollow shaft
- Suitable for safe motor feedback according to IEC 61800-5-2
- Radial or axial electrical connection via connectors M12, M23 or cable
- Adapted anti-rotation system available (stator coupling, tether arm)

INTERFACE FEATURES

- Output: square-wave pulses A, A/, B, B/, Z, Z/
- Level: TTL (RS422) or HTL
- Output: Sine / Cosine S, S/, C, C/, Z, Z/
- Level SIN/COS: 1 Vpp
- 250 to 2500 counts per 360°

TECHNICAL DATA
ELECTRICAL DATA

Operating voltage	5 VDC ($\pm 5\%$) or 11 to 30 VDC, reverse polarity protected and short-circuit proof *
Supply type	Power supply according to Class 2 LPS or SELV/PELV limited energy source $\leq 60V$
Supply ripple max.	250 mV
Electrical connection	Via connector M12, M23 or cable - radial

OUTPUT: PULSES

Supply current max.	100 mA with no load 220 mA with load
Output current max.	40 mA by pair
Output	Digital TTL (RS422) Digital HTL (only $V_s = 11$ to 30 VDC)
Output signal frequency	300 kHz depending on cable length
Load @ TTL	100 to 240 ohms
Load @ HTL	750 to 3000 ohms @ 30 VDC 600 to 3000 ohms @ 24 VDC 275 to 3000 ohms @ 11 VDC
Response time	4 μ s typical
Phasing tolerance	$90^\circ \pm 10^\circ$
Duty cycle	50% $\pm 5\%$
Jitter	$< 2\%$
Output voltage levels TTL	Low: min. 0 V, typ. 0.5 V, max. 2.5 V High: min. 3.5 V, typ. 4.8 V (+ $V_s - 0.5$ V @ 5 VDC), max. 5.4 V (+ V_s @ 5 VDC)
Output voltage levels HTL	Low: min. 0 V, typ. 0.5 V, max. 2.5 V High: min. + $V_s - 3V$, typ. + $V_s - 0.5$ V, max. + V_s

OUTPUT: SIN/COS

Supply current max.	70 mA with no load and 100 mA with load
Output current max.	10 mA by pair
Output	SIN/COS with 1 Vpp
Output signal frequency	300 kHz depending on cable length
Load	100 to 240 ohms
Response time	2 μ s typical
Phasing tolerance	$90^\circ \pm 10^\circ$
Harmonics	< -45 db
Amplitude tolerance per signal	500 mVpp $\pm 20\%$
Amplitude difference between signals	≤ 50 mV
Offset value per signal	2.5 V ± 500 mV
Offset difference between signals	≤ 50 mV

MECHANICAL DATA

Operating speed max.	9000 rpm @ both types
Operation speed cont.	6000 rpm @ both types
Static torque	0.01 Nm @ blind hollow shaft, 0.005 Nm @ tapered blind hollow shaft
Dynamic torque	0.085 Nm @ blind hollow shaft, 0.035 Nm @ tapered blind hollow shaft
Shaft inertia	< 67 gcm ² @ blind hollow shaft, < 28 gcm ² @ tapered blind hollow shaft
Perm. shaft load	20 N axial @ blind hollow shaft, 40 N axial @ tapered blind hollow shaft 40 N radial @ blind hollow shaft, 80 N radial @ tapered blind hollow shaft
Theoretical mechanical lifetime L_{10h}	24.0 x 10 ⁹ turns / 100,000 hours ** @ blind hollow shaft 29.7 x 10 ⁹ turns / 82,365 hours ** @ tapered blind hollow shaft
Material	Body: aluminium Cover: coated zinc alloy (@ blind h. s.) or cast zinc alloy or aluminium (@ taper. b.h.s.) Shaft: stainless steel 1.4305 (AISI 303)
Bearings	6803 series - sealed @ blind hollow shaft 6000 series - sealed @ tapered blind hollow shaft
Mass	~ 0.30 kg @ both types

 * Not to + V_s at TTL and SIN/COS @ 11 to 30 VDC each. $V_s = 5$ VDC ($\pm 5\%$) must be monitored

 ** Continuous max. speed – ½ max. load – according to ISO 281: 1990, L₁₀

TECHNICAL DATA
ENVIRONMENTAL DATA

Operating temperature	-20 to +85 °C (encoder T°)
Storage temperature	-20 to +85 °C
Humidity	93 % @ 65 °C (EN 60068-2-38)
Resistance against shock	≤ 100 m/s ² @ blind hollow shaft, 500 m/s ² @ tapered b. h. s. (EN 60068-2-27, 6 ms)
Resistance against vibration	≤ 100 m/s ² @ both types (EN 60068-2-6, 10 (blind h. s.) resp. 55 (tapered b.h.s.)... 2000 Hz)
Protection grade	IP65
Isolation	1000 V _{eff}
EMC immunity test	EN 61000-6-2, increased levels
EMC emission test	EN 61000-6-4, increased levels
Salt spray test	96 h (EN 60068-2-11, part 2)

SAFETY DATA

Z and Z/ are not safety signals (@ pulses and SIN/COS)

Applied functional safety standards	IEC 61508 IEC 62061 ISO 13849-1 IEC 61800-5-2
-------------------------------------	--

Maximum operating life 20 years

Further safety data See handbook [SOI17141](#)

OUTPUT: SQUARE-WAVE PULSES FOR POSITION SENSING APPLICATIONS (@+40 °C, SINGLE CHANNEL)

Time for output signal initialization after power on	~30 ms
Time for internal monitoring activation after power on	250 ms (560 ms max.)
Time to switch off outputs in case of error	< 200 ms
High impedance output leakage current	±10 µA

V_s = 5 VDC (± 5 %):

PFD (IEC 61508, 1/h)	7.51x10 ⁻⁵
PFH (IEC 61508, 1/h)	8.58x10 ⁻¹⁰
MTTFd (ISO 13849, years)	1331
DC	99 %

V_s = 11 to 30 VDC:

PFD (IEC 61508, 1/h)	9.52x10 ⁻⁵
PFH (IEC 61508, 1/h)	1.09x10 ⁻⁹
MTTFd (ISO 13849, years)	1050
DC	99 %

OUTPUT: SINCOS FOR POSITION SENSING APPLICATIONS (@+40 °C, SINGLE CHANNEL)

Time for output signal initialization after power on	~30 ms
Time for internal monitoring activation after power on	~30 ms
Time to switch off outputs in case of error	< 50 µs
High impedance output leakage current	±1 µA

V_s = 5 VDC (± 5 %):

PFD (IEC 61508, 1/h)	4.29x10 ⁻⁵
PFH (IEC 61508, 1/h)	4.90x10 ⁻¹⁰
MTTFd (ISO 13849, years)	2328
DC	99 %

V_s = 11 to 30 VDC:

PFD (IEC 61508, 1/h)	6.60x10 ⁻⁵
PFH (IEC 61508, 1/h)	7.53x10 ⁻¹⁰
MTTFd (ISO 13849, years)	1515
DC	99 %

PRODUCT CHARACTERISTICS - SIGNAL OUTPUT

First safety channel with signal A or S and inverted signal A/ or S/. Second safety channel with signal B or C and inverted signal B/ or C/. Third channel not for safety with signal Z and inverted signal Z/.

SQUARE-WAVE PULSES

Channel 2 (B) before channel 1 (A) (90° period phase shift), clockwise shaft rotation viewed from flange side.

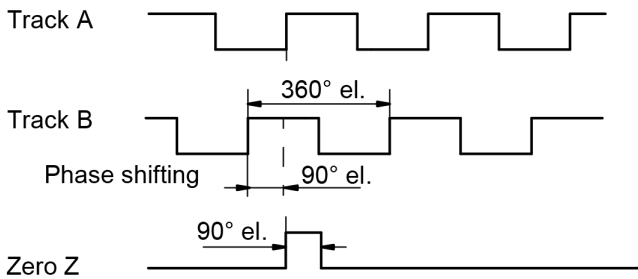

SIN/COS

Channel 2 (cosine) before channel 1 (sine) (90° period phase shift), clockwise shaft rotation viewed from flange side.

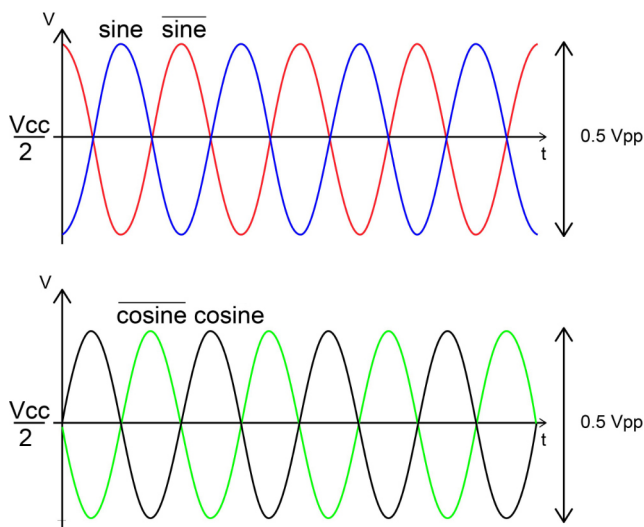

ELECTRICAL CONNECTION - PINOUT

CONNECTOR OUTPUT M23, 12-PIN, MALE, CCW

PIN	Function
1	A/ or S/
2	+ V _S
3	Z
4	Z/
5	B or C
6	B/ or C/
7	n.c.
8	A or S
9	n.c.
10	- V _S (0 V / GND)
11	- V _S (0 V / GND)
12	+ V _S
Connector body	Ground

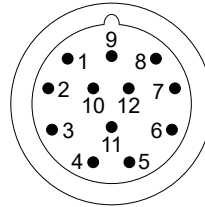

CONNECTOR OUTPUT M12, 8-PIN, MALE, A-CODED

PIN	Function
1	- V _S (0 V / GND)
2	+ V _S
3	A or S
4	B or C
5	Z
6	A/ or S/
7	B/ or C/
8	Z/
Connector body	Ground

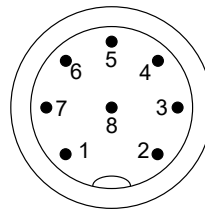

ELECTRICAL CONNECTION CABLE OUTPUT - PVC, 8-WIRES, 8230 / 020 (FURTHER CABLES ON REQUEST)

Colour	Function
WH white	- V _S (0 V / GND)
BN brown	+ V _S
GN green	A or S
YE yellow	B or C
GY grey	Z
PK pink	A/ or S/
BU blue	B/ or C/
RD red	Z/
General shielding	Ground

ORDER CODE FORMAT
SOI | **58** | **HK** | **7,3** | **1** | **1** | **0** | **A** | **1024** | **2** | **6** | **S3** | **H** | **01** | **STANDARD VERSION**

SOI	Incremental rotary encoder - SIL3 / PLe/CAT4		
58	Design form Ø	58	Design form 58
HK	Flange	HB HK	Flange with blind hollow shaft Flange with blind hollow shaft 7,3 mm, tapered 10 %
7,3	Hollow shaft Ø	7,3 10 12 14	7,3 mm, tapered 10 % (only at flange HK) 10 mm (only at flange HB) 12 mm (only at flange HB) 14 mm (only at flange HB) (other values at flange HB, e.g. 9.52 mm or 12.7 mm on request)
1	Protection grade	1	IP65
1	Electrical connection	1 2 3 4 5 6	1 x connector M23, CCW, radial 1 x connector M23, CCW, axial 1 x cable, PVC, 8-wire, axial (further cables on request) 1 x cable, PVC, 8-wire, radial (") 1 x connector M12, radial 1 x connector M12, axial
0	Cable length	0 2 5 10	Insert 0 at connector output 2 m 5 m 10 m (e.g. 0,15 for 15 cm or 1,5 for 1.5 m)
A	Housing material	A	Aluminium / coated zinc alloy / cast zinc alloy
1024	Resolution	250 256 360 500 512 1000 1024 1500 2000 2048 2500	Square-wave pulses or nr. of SIN/COS per 360°
2	Supply voltage	1 2	5 VDC (±5 %) 11 to 30 VDC
6	Output signal	6	A, A/, B, B/, Z, Z/ (signal form T or H) or S, S/, C, C/, Z, Z/ (signal form S)
S3	Profile (Certificate)	S3	SIL3 and PLe/CAT4 certified as specified in this data sheet
H	Signal form	T H S	TTL (RS422) HTL (only at Vs = 11 to 30 VDC) SIN / COS (1 Vpp)
01	Electrical and mechanical variants*	01	Standard version

* The basic versions according to the data sheet bear the number 01. Deviations are identified with a variant number and are documented in the factory.

ACCESSORIES (SELECTION)

STATOR COUPLING AND TETHER ARM FOR DESIGN FORM SOI58-T - ON REQUEST

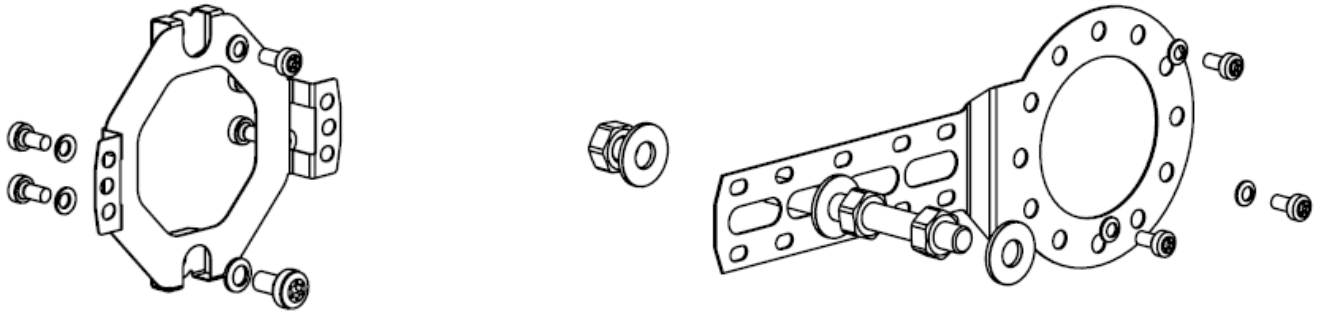

CONNECTING CABLE FOR CONNECTORS M12, 8-PIN, A-CODED AND M23, 12-PIN, CCW - ON REQUEST

Please ask our technical staff for detailed drawings for the accessories.

DOCUMENTATION

The following documents can be found in the Internet under www.twk.de in the documentation area, model SOI58-H/S3.

Data sheet	SOI17198
Manual	SOI17141
Installation instructions	AN16169
SIL3 / PLe certificate	SOI17204
EC Declaration of Conformity	ZE17199
Reach compliant	QS15286
RoHS compliant	QS13284

INSTALLATION DRAWINGS

MODEL SOI58HB14110A102426S3H01

Dimensions in mm

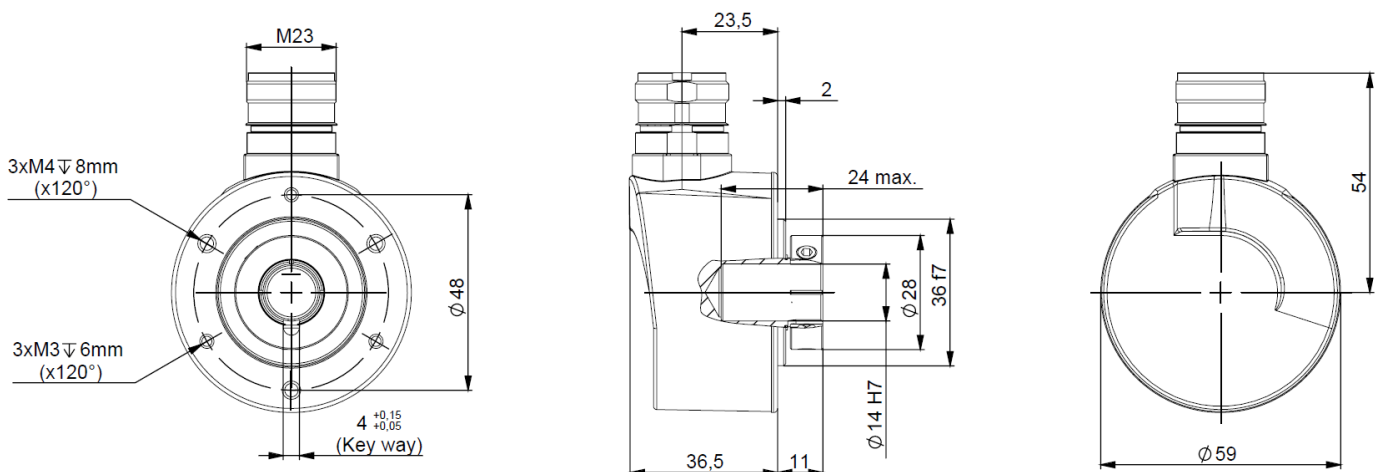

INSTALLATION DRAWINGS

MODEL SOI58HB10160A102426S3H01

Dimensions in mm

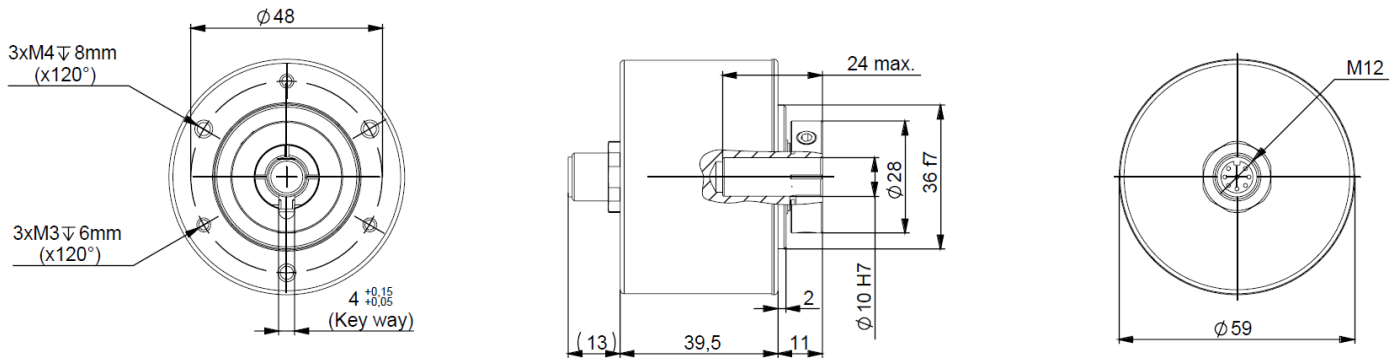

MODEL SOI58HK7,3150A102426S3H01

Dimensions in mm

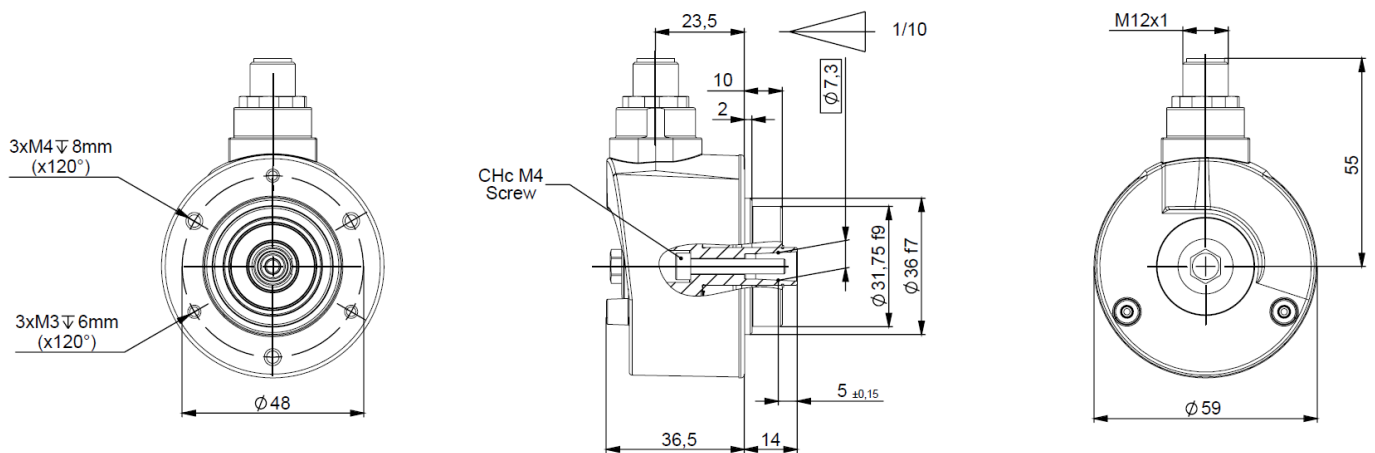

MODEL SOI58HK7,3160A102426S3H01

Dimensions in mm

