

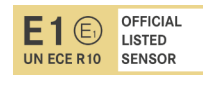

- Dynamic inclination sensor
- MEMS-accelerometer and MEMS-gyroscope
- Safety inclination output for 2 axes (configurable through SDO)
- Standard measuring ranges:
 - One axis: 360 ° (± 180°)
 - Two axes: ± 90°
- Safety rotation rate output for 3 axes
- Safety acceleration output for 3 axes
- Active temperature compensation
- Housing: zinc die cast
- Protection type: IP6K5 / IPX7
- TÜV certified: SIL2 and PLd



KEY INFORMATION OVERVIEW

DESIGN & FUNCTION

The inclinometer measures the inclination in the gravitational field by means of MEMS sensors (Micro-Electro-Mechanical-System).

By combining MEMS acceleration sensors and MEMS angular rate sensors, each with 3 measuring axes, it is possible to generate an inclination signal that is insensitive to disturbing accelerations. Disturbing accelerations can be caused by vibrations and other accelerations (e.g. curve movements or changes in speed). The resulting signal is transmitted by PDOs and can be used for fast and accurate control of movements.

All measured raw variables are recorded and processed in a functionally safe manner in order to obtain a stable inclination signal that corresponds to a SIL2/PLd safety level. Filtering can be selected and adjusted by the customer to match the NBN45-G/S3 to the application and therefore to achieve the best result.

The individual measured variables for each axis of acceleration and angular rate can also be read out separately.

The NBN45-G/S3 has a stable zinc die cast housing with a robust design for use in harsh environments. An integrated heater enables the customer to operate an active temperature compensation.

It is equipped with a status LED and two connectors M12-A for CANopen bus loop use.

Different mechanical alignments of the NBN43/S3 for several mounting situations in the application can be selected through customer via CAN parameter (see [page 4](#)).

FEATURES INTERFACE

The NBN45-G/S3 is equipped with a CAN interface with the following transmission protocols/profiles, which can be selected via CAN parameter:

- CANopen
- CANopen Safety
- SAE J1939

It is short-circuit protected and can be operated with a bit rate up to 1000 kBit/s.

A status LED (green / red) indicates normal operating status or errors according to CiA DR-303-3.

Via CAN parameters the NBN45-G/S3 can be parameterized and configured in many ways.

A detailed description of the NBN45-G/S3 and the interface with CANopen / SAE J1939 protocol can be found in the [NBN17382](#) manual (in preparation).

TECHNICAL DATA

DIAGNOSIS LED

LED 1 (green / red) normal run state / error state, different flashing modes

MECHANICAL DATA

Housing material zinc die cast
Dimensions 83 mm x 73 mm x 26 mm
Weight 0.25 kg

ENVIRONMENTAL DATA

Temperature range - 40 °C to + 85 °C
Storage temp. range - 40 °C to + 85 °C
Resilience to shock 50 g, 6 ms, half sine, @ room temp., DIN EN 60068-2-27
Protection grade IP6K5 / IPX7

EMC STANDARDS

Selection, for complete list of standards and fulfilled values see manual [NBN17382](#).
DIN EN 61326-1:2013 / DIN EN 61000-4-3 . Immunity - For electrical equipment for measurement, control and laboratory use - Radiated, radio-frequency, electromagnetic field immunity test
EN 61326-1:2013 (and 2021) / EN IEC 61000-6-2:2019 / DIN EN 61000-4-6 Immunity to conducted disturbances, induced by radio-frequency fields - supply and data lines
EN 61326-1:2013 (and 2021) / DIN EN 61000-4-8. Immunity - Electrical equipment for measurement, control and laboratory use - magnetic field

SAFETY DATA

According to IEC 61508 PFH ≤ 6.5 x 10⁻⁸ 1/h (soft errors included)
SFF ≥ 90 %
HFT = 0
SIL2
According to ISO 13849-1 MTTFd = 136.5 years (soft errors included)
DCavg = 92.2 %
Categorie 2
Performance Level D
Maximum operating duration 20 years

FURTHER APPLICABLE STANDARDS

E1 approval according UN ECE Regulation No. 10, No. 10R - 06 10285

PROGRAMMABLE PARAMETERS

Please refer to manual [NBN17382](#) for programmable parameters.

CAN OUTPUT LEVEL ACCORDING TO ISO/DIS 11898

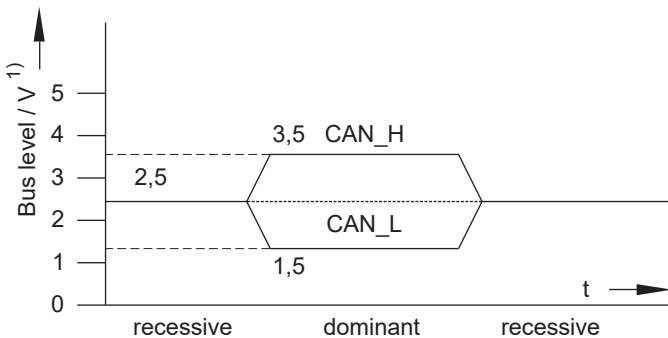

1) with common mode voltage= 0V

CANBUS ACTIVATION ACCORDING TO ISO / DIS 11898

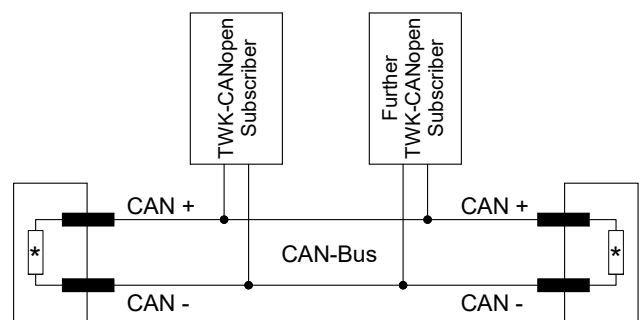

* Terminating resistor (120 Ω)

PRODUCT CHARACTERISTICS

INSTALLATION POSITION AND MEASUREMENT AXES

The installation position TOP 1...6 of the inclination sensor determines, which axes are used for the inclination angles with respect to the sensor housing. There are six possible installation positions corresponding to the six sides of the sensor. The standard installation position is TOP 1. The illustration below shows how the two measuring axes x and y (each +/- 90°) are aligned at the 2-axis sensor with TOP 1 (i. e. in the horizontal plane). With the 1-axis sensor, the z-axis is the measuring axis (0 to 360°) and is perpendicular to the x and y axes at installation position TOP 1. For measurement, the sensor has to be rotated 90° so that the z-axis is horizontal. If it points backwards (connectors facing downwards at TOP 1), ± 180° can be measured.

The same procedure applies to the other installation positions TOP 2 to TOP 5. The side of the housing that is aligned upwards in each case and the position of the coordinate system can be seen in the illustrations below. For each installation position TOP 1...6, the x and y axes of the 2-axis sensor are already in the horizontal plane and, for measurement with the 1-axis sensor, the z-axis must be turned horizontal. This must be taken into account for mechanical alignment and the order code ([page 6](#)).

The installation position can be modified by customer by using the parameter CS_ROT (coordinate system rotation, 0 = TOP 1 to 5 = TOP 6, see manual [NBN17382](#), chapter 8.3). Definitions of acceleration output and angular speed output are described in the manual as well.

INSTALLATION POSITION TOP 1 - 2 AXES SENSOR

NBN45 - Z 90/90/0 G S3 - 1 - S2 N01

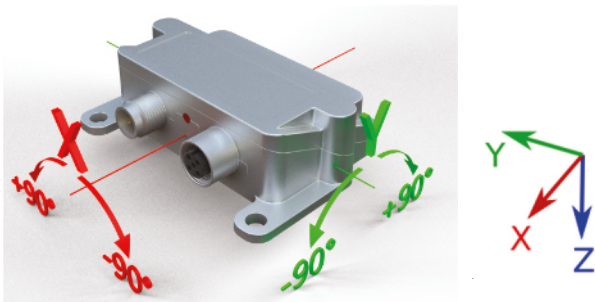

INSTALLATION POSITION TOP 1 - 1 AXIS SENSOR

NBN45 - Z 0/0/180 G S3 - 1 - S2 N01

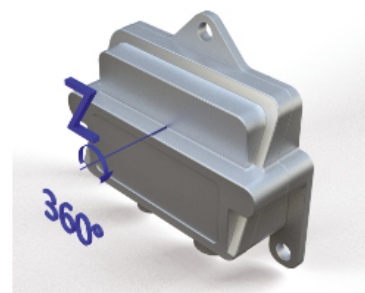

INSTALLATION POSITIONS TOP 2 TO TOP 6

TOP 2



TOP 3

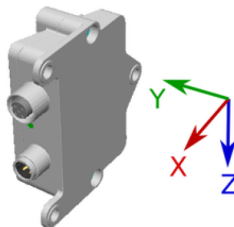

TOP 4

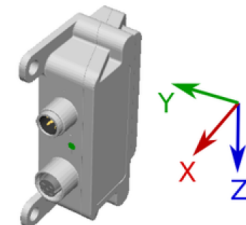

TOP 5

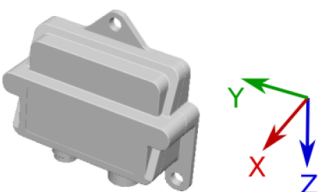

TOP 6



TECHNICAL DATA

PRINCIPAL DIAGRAM OF SIGNAL FLOW

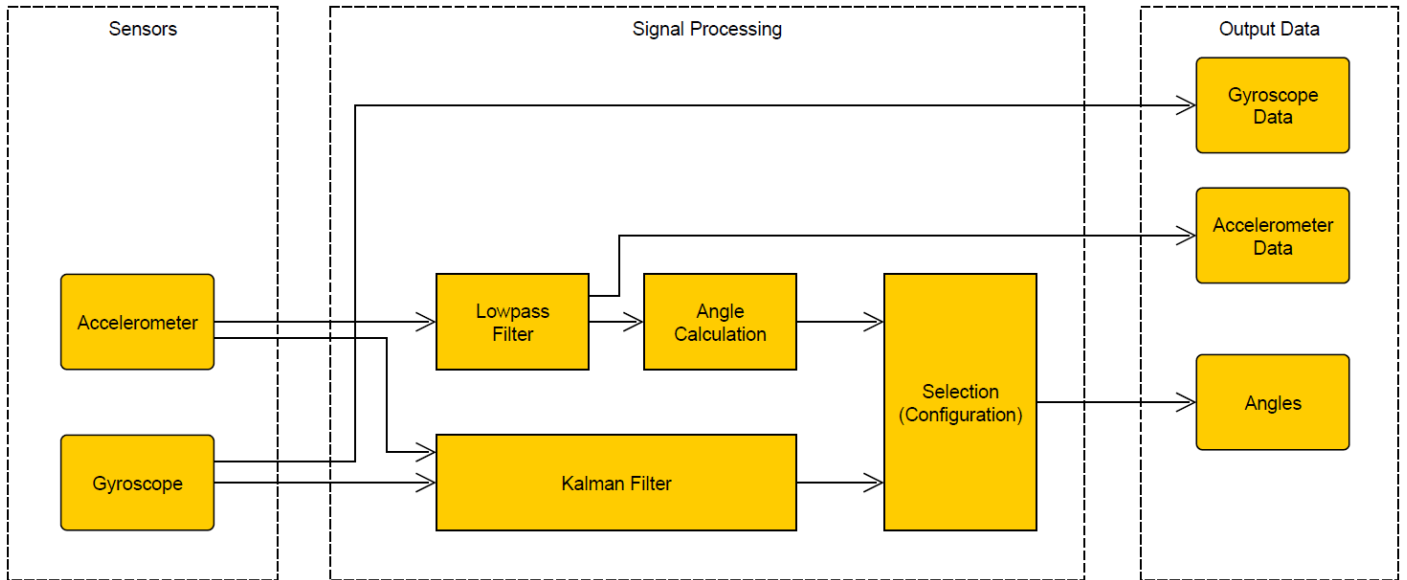

ELECTRICAL CONNECTION

ELECTRICAL CONNECTION

2 x M12 connector A-coded, 5-pole, male and female for bus in / bus out and power supply.
The connection assignment TYxxxxx is part of the scope of supply and is included with each device.

CONNECTOR FOR SUPPLY AND CANOPEN (BUS IN AND BUS OUT)

PIN	Function
1	shield (PE, housing)
2	+ V _S (power supply)
3	- V _S , GND (common ground)
4	CAN_High
5	CAN_Low

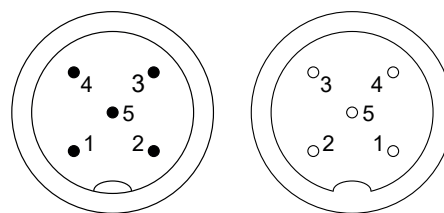

REMARK

Only use shielded cable for power supply and CANopen.

ORDER CODE FORMAT

NBN **45 -** **Z** **90 / 90 / 0** **G** **S3** **- 1 -** **S** **2** **N** **01** **STANDARD VERSION**

NBN	Inclination sensor with CANopen Safety / SAE J1939 interface		
45	Design form	45	Design form 45 mm
Z	Housing material	Z	Zinc die cast
90	Measuring range x	0 90	x-axis (± 90° for two axes or ± 0° for one axis)
90	Measuring range y	0 90	y-axis (± 90° for two axes or ± 0° for one axis)
0	Measuring range z	0 180	z-axis (± 0° for two axes or ± 180° for one axis)
G	Type of inclination sensor	G	Dynamic inclination sensor with gyroscope
S3	Profile	S3	SIL2 / PLd certified according to this data sheet
1	Installation position	1, 2, 3, 4, 5, 6	TOP position: see page 4 and below: available types
S	Electrical connection (kind)	S	Connector M12-A, 5-pole
2	Electrical connection (number)	2	2 x connector, male / female
N	Output	N	CANopen Safety / SAE J1939
01	Electrical and mechanical variants*	01	Standard

AVAILABLE TYPES

(Standard versions. Other measuring ranges and installation positions on request)

NBN45 - Z 90 / 90 / 0 G S3 - 1 - S2 N 01

NBN45 - Z 0 / 0 / 180 G S3 - 1 - S2 N 01

* The basic versions according to the data sheet bear the number 01. Deviations are identified with a variant number and are documented at TWK.

ACCESSORIES (TO BE ORDERED SEPARATELY)

MATING CONNECTORS

Order number, Datasheet	Type	Design & wire fixing	Housing-material	Cable \varnothing & wire size	Shielding & IP grade
STK5GS56, –	M12-A 5-pole, female	Straight screws	Zinc die cast, nickel-plated	6 – 8 mm $\leq 0.75 \text{ mm}^2$	On housing IP67
STK5GP90, –	M12-A 5-pole, male	Straight screws	Zinc die cast, nickel-plated	6 – 8 mm $\leq 0.75 \text{ mm}^2$	On housing IP67
STK5WS58, –	M12-A 5-pole, female	Angled, screws	Zinc die cast, nickel-plated	6 – 8 mm $\leq 0.75 \text{ mm}^2$	On housing IP67
STK5WP102, –	M12-A 5-pole, male	Angled, screws	Zinc die cast, nickel-plated	6 – 8 mm $\leq 0.75 \text{ mm}^2$	On housing IP67

DOCUMENTATION

DOCUMENTATION

The following documents can be found in the Internet under www.twk.de/en in the documentation area, model NBN-G/S3

- Data sheet [NBN17266](#)
- Manual [NBN17382](#)
- CE Declaration of Conformity [ZE12467](#)
- UKCA Declaration of Conformity [ZE16569](#)
- Reach-compliant [QS15286](#)
- RoHS-compliant [QS13284](#)
- POP Declaration of Conformity [QS17238](#)
- Installation instructions [AN16169](#)

INSTALLATION DRAWING

MODEL NBN45 - Z X / Y / 0 G S3 - TOPX - S2 N 01

